

Spur Gearhead GS 12 A $\varnothing 12$ mm, 0.01–0.03 Nm

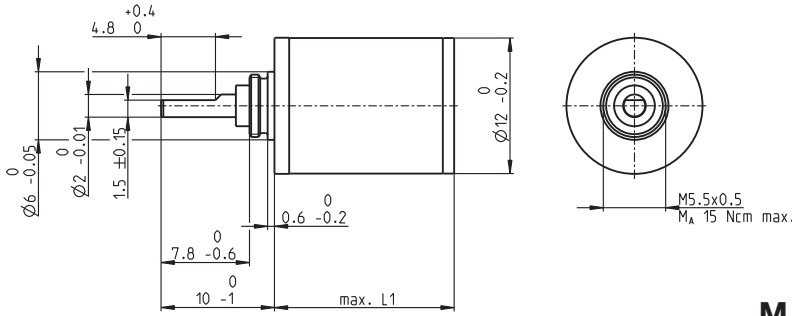

Technical Data

Spur Gearhead	straight teeth
Output shaft	stainless steel, hardened
Bearing at output	sleeve bearing
Radial play, 6.5 mm from flange	max. 0.05 mm
Axial play	0.02–0.12 mm
Max. axial load (dynamic)	2 N
Max. force for press fits	30 N
Max. continuous input speed	8000 rpm
Recommended temperature range	-15...+100°C
Extended range as option	-40...+100°C
Max. radial load, 6.5 mm from flange	2 N

M 3:2

- Stock program
- Standard program
- Special program (on request)

Part Numbers

	310301	313872	313990	313991	310311	313993	310316
Gearhead Data							
1 Reduction	6.4:1	13:1	58:1	141:1	371:1	485:1	3101:1
2 Absolute reduction	$\frac{403}{63}$	$\frac{21866}{1694}$	$\frac{724594}{12474}$	$\frac{20138716}{142884}$	$\frac{26782109}{72171}$	$\frac{624300196}{1285956}$	$\frac{11537547853}{3720087}$
3 Max. motor shaft diameter	mm 1.2	1.0	1.0	1.2	1.0	1.2	1.2
Part Numbers	310302	310304	310307	313992		310313	310317
1 Reduction	9.1:1	22:1	76:1	200:1		900:1	4402:1
2 Absolute reduction	$\frac{899}{99}$	$\frac{12483}{567}$	$\frac{387283}{5103}$	$\frac{22462414}{112266}$		$\frac{372178963}{413343}$	$\frac{25737606749}{5845851}$
3 Max. motor shaft diameter	mm 1.0	1.2	1.2	1.0		1.2	1.0
Part Numbers		310305	310308	310310		310314	
1 Reduction		31:1	108:1	261:1		1278:1	
2 Absolute reduction		$\frac{27869}{891}$	$\frac{863939}{8019}$	$\frac{12005773}{45927}$		$\frac{830245379}{649539}$	
3 Max. motor shaft diameter	mm	1.0	1.0	1.2		1.0	
4 Number of stages		2	3	4	5	5	6
5 Max. continuous torque	Nm	0.010	0.015	0.020	0.025	0.025	0.030
6 Max. intermittent torque at gear output	Nm	0.030	0.035	0.040	0.045	0.045	0.050
12 Direction of rotation, drive to output		=	≠	=	≠	=	≠
7 Max. efficiency	%	81	73	66	59	59	53
8 Weight	g	6.5	7.4	8.3	9.2	9.2	10.1
9 Average backlash no load	°	1	1	1.2	1.2	1.2	1.2
10 Mass inertia	gcm ²	0.002	0.002	0.002	0.002	0.002	0.002
11 Gearhead length L1	mm	10	12	14	16	16	18



maxon Modular System

+ Motor	Page	+ Sensor/Brake	Page	Overall length [mm] = Motor length + gearhead length + (sensor/brake) + assembly parts								
A-max 12	191/192			31.3	33.3	35.3	37.3	37.3	39.3	41.3		
A-max 12, 0.5 W	192	MR	385/386	35.4	37.4	39.4	41.4	41.4	43.4	45.4		