

DC-max 16 S Precious Metal Brushes

DC motor Ø16 mm

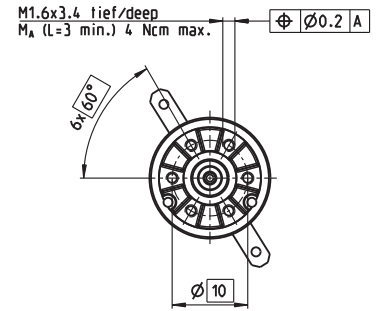

2/4.3 W 4.1 mNm 11000 rpm

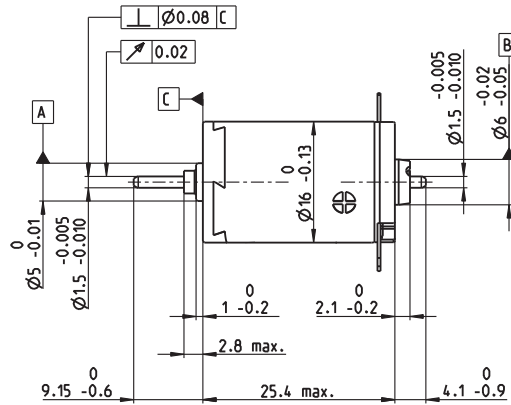
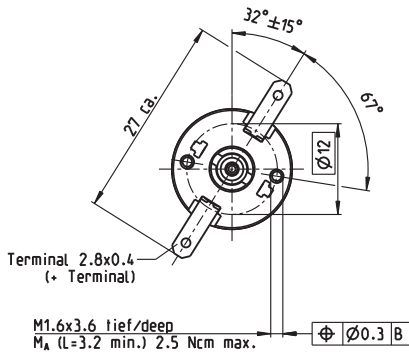

M 1:1

Motor Data

1_	Nominal voltage	V	6	12	24
2_	No load speed	rpm	7890	7560	7470
3_	No load current	mA	14.7	6.90	3.40
4_	Nominal speed	rpm	4830	4390	4210
5_	Nominal torque (max. continuous torque)	mNm	4.06	3.92	3.80
6_	Nominal current (max. continuous current)	A	0.577	0.267	0.128
7_	Stall torque	mNm	10.5	9.44	8.75
8_	Stall current	A	1.46	0.629	0.289
9_	Max. efficiency	%	81	80	80
10_	Terminal resistance	Ω	4.10	19.1	83.2
11_	Terminal inductance	mH	0.140	0.610	2.49
12_	Torque constant	mNm/A	7.19	15.0	30.3
13_	Speed constant	rpm/V	1330	637	315
14_	Speed/torque gradient	rpm/mNm	758	809	864
15_	Mechanical time constant	ms	8.87	8.92	9.00
16_	Rotor inertia	gcm ²	1.12	1.05	0.994

Thermal data

17_	Thermal resistance housing-ambient	K/W	29.8
18_	Thermal resistance winding-housing	K/W	5.5
19_	Thermal time constant winding	s	5.35
20_	Thermal time constant motor	s	288
21_	Ambient temperature	°C	-30...+65
22_	Max. winding temperature	°C	85

Operating Range

n [rpm] Winding 12 V

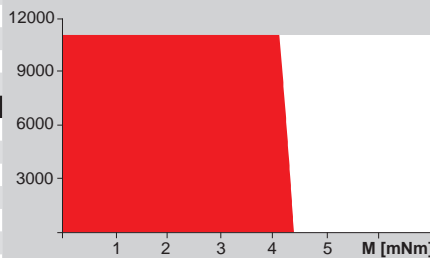

■ Continuous operation
■ Continuous operation with reduced thermal resistance R_{th2} 50%
■ Intermittent operation

Mechanical data ball bearings

23_	Max. speed	rpm	11000
24_	Axial play	mm	0.15...0.05
	Preload	N	0
25_	Radial play	mm	0.025
26_	Max. axial load (dynamic)	N	2.2
27_	Max. force for press fits (static) (static, shaft supported)	N	30
28_	Max. radial load [mm from flange]	N	200
		N	7.8 [5]

Mechanical data sleeve bearings

23_	Max. speed	rpm	11000
24_	Axial play	mm	0.15...0.05
	Preload	N	0
25_	Radial play	mm	0.012
26_	Max. axial load (dynamic)	N	0.8
27_	Max. force for press fits (static) (static, shaft supported)	N	35
28_	Max. radial load [mm from flange]	N	200
		N	1.4 [5]

Other specifications

29_	Number of pole pairs		1
30_	Number of commutator segments		7
31_	Weight of motor	g	23.3

maxon Modular System

maxon gear	Stages	maxon sensor	maxon motor control
122_GPX 16 A/C	1-2	146_ENX 10 QUAD	416_ESCON Module 24/2
123_GPX 16 LN/LZ	1-2	146_ENX 10 EASY	416_ESCON 36/2 DC
126_GPX 19 A/C	3-4		424_EPOS2 24/2 (DC/EC)
127_GPX 19 LN/LZ	3-4		424_EPOS2 Module 36/2
			435_MAXPOS 50/5

Configuration

Bearing: Sleeve bearings/ball bearings
 Commutation: Precious metal brushes with CLL/Graphite Brushes
 Shaft front/back: Length
 Electric connection: Terminals/cable